

# TESA MULTIGAUGING

With inductive probes

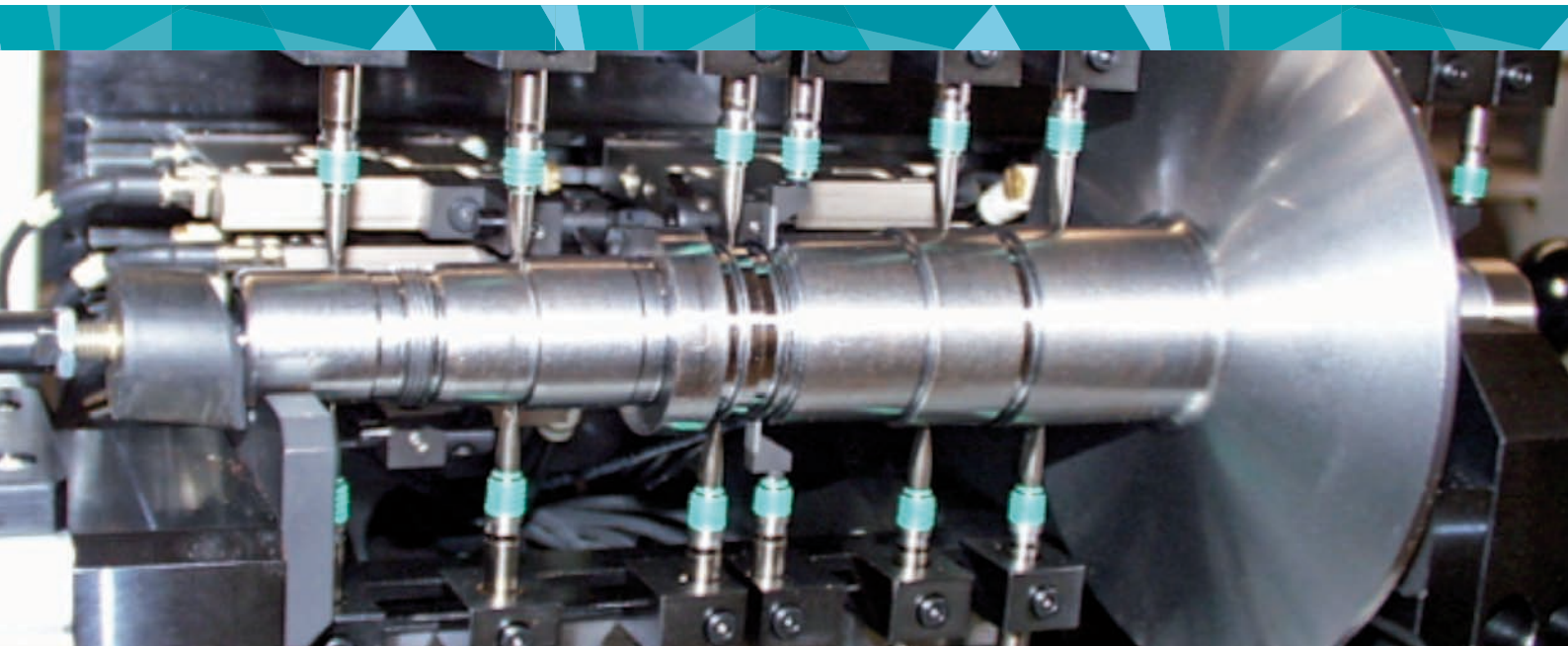

When sub-micron accuracy and productivity are required...

**Inductive probes cannot be beaten for quick, accurate and repeatable multidimensional measurements. Comparative measurement determines the deviation of the workpiece with respect to a calibration standard.**

This technology has applications in the automotive, aeronautical and machine-tool industries. Probes are generally used for quality assurance in a laboratory setting and to check the dimensional tolerances of finished parts in production.

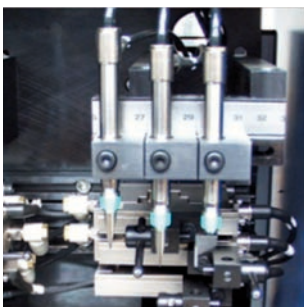

## Interfacing, measuring functions and statistical process control of data

TESA BPX is an electronic interface for inductive probes, managing and synchronising probes for static or dynamic measurement operations. Multiple BPX units can be connected in series, allowing up to 64 probes to be managed simultaneously. The interface provides a full range of interfacing options, depending on client requirements:

### Customised applications for the shop floor for static and dynamic measurements

Industrial applications – TESA Vario SPC software. Calls up test plans, creates test orders, displays measurement results with test maps, provides full indicators and statistics, exports test plans and results in a range of file formats.

Direct communication with the BPX interface, by using direct commands or by using the DLL library (C+) available.

**Customised solution** – communicate directly with the BPX interface with your own custom-developed software using direct commands or a DLL (in C language)

**Simple stats application** to manage measurement programmes and statistical data with simple SPC software - TESA StatExpress

**Simple turnkey application** - TESA Interface Software (TIS)



TESA Vario SPC



BPX44

TESA Interface Software



TESA Stat-Express

## Modular Fixtures

Module-based fixtures allowing different configurations by using standard mechanic components available in digitalised CAD format file

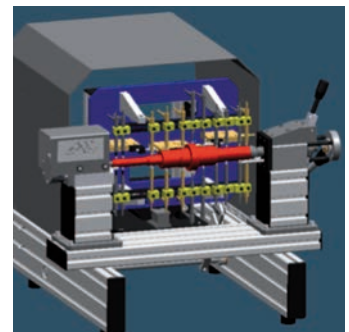
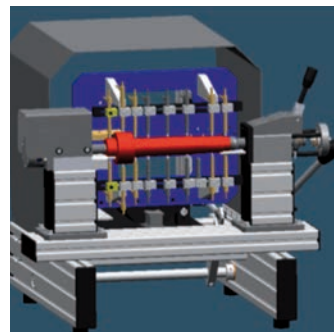
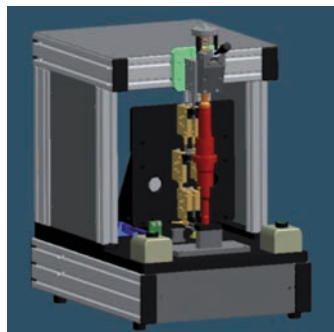
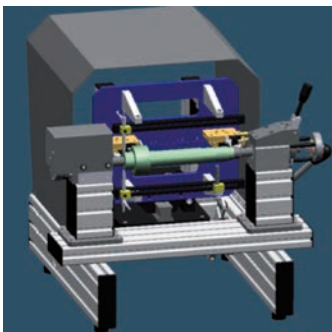



# Application taper disk

## Measurement device characteristics

Workpiece loading	Manual
Measurement procedure	Automatic
Measurement type	Static measurements. 7 diameters and 8 lengths
Instruments	23 axial TESA inductive probes (FMS)
Features:	VARIO modular system, requires very few custom parts (15%)

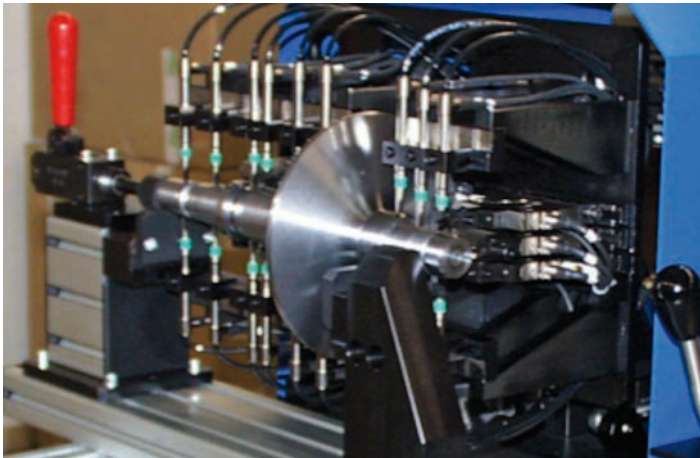

Overview



probing system

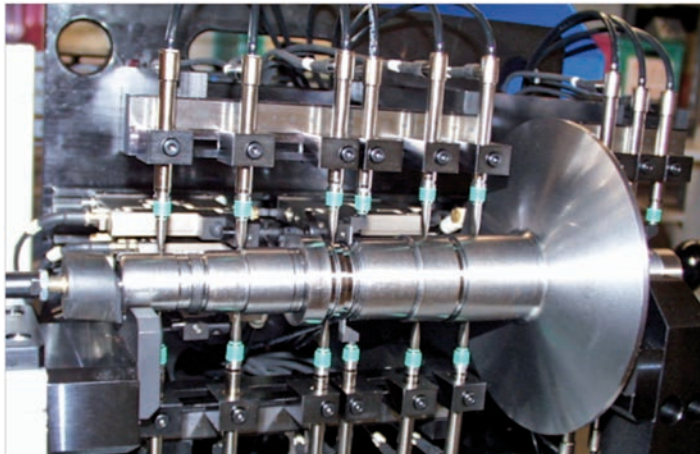

Application view

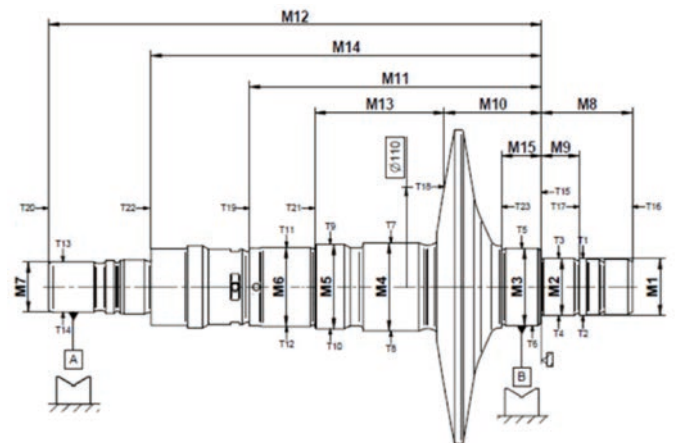

Diagram of measurement plan

## Application Gear wheel

### Measurement device characteristics

Workpiece loading	Manual
Measurement procedure	Automatic
Measurement type	Static measurements. 3 diameters and 2 lengths
Instruments	10 TESA inductive probes (FMS and axial)
Features:	VARIO modular system, requires 30% custom parts



Application view

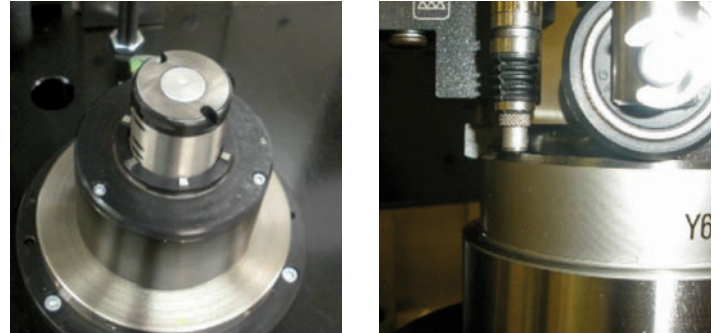

Detailed view

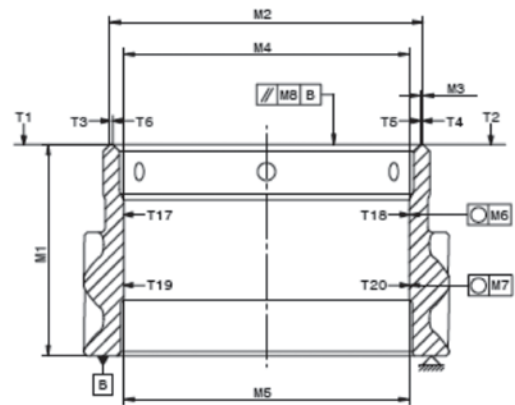

Diagram of measurement plan

## Application Input shaft

The two identical fixtures are integrated in a manufacturing line, each one supporting one soft turning machine. By using the SPC functions in the measurement software in a feedback loop this customer can maintain an extra stable manufacturing process.

Six different input shafts are presently manufactured in this line, it is fully automatic and can run unmanned production for 24h/7d. Operators are normally only handling the change to a new part and restart after failure. The settings are handled by changing to the measuring plate corresponding to the produced part from a set of four plates. Together with selecting one of three adapted measuring centers for the inside dimensions. All changes are supported from the operator panel and confirmed by sensors to the program.

When setting the turning machines to new tools also the measuring fixture must get the corresponding setup else the loading will get blocked. The operator only needs to specify a part number and gets guided by the panel to select necessary settings for this part. Typically changing to the adapted measuring plate and the inside measuring unit will take less than 5 min.

When everything is set as expected it is possible to continue in the program by zeroing all the measures. The operator must manually load a master part with calibrated dimension into the fixture. During all manual operation all movements are controlled by a regular safety system with activation balls for the operator.

After this the fixture can be switched to automatic mode and left closed in the manufacturing cell. During the production cycle finished parts are placed in the fixture by the loading gantry robot. After measuring, all approved parts are moved to a pallet on the conveyer track. The system now evaluated all dimension to the tolerances in the program and the selected measurement deviation will feedback control values to the manufacturing machines, keeping the produced parts within its tolerances. All measured data are stored in the program database for production evaluation.



Application view



Integration in production





## Application Puffer circuit breaker

The intention of this fixture is to check placement of the connector ring inside the formed copper tube after the assembly. The operator is manually loading the fixture and instantly get an evaluation if the part is in specification or not, with low risk of influence from the handling. The fixtures are placed on a table in the workshop and manually loaded with the puffer tubes. The dimensions are calculated by software and the operator can register the maximum value of the parallelism by turning the part.

Before starting the measurements on a batch the operator needs to setting transducer zero by selecting the mastering operation with the precisely manufactured master part. The transducers 4 for each inner diameter and 3 on a plane for the length can be read from the electronics with measurement computer. The software are presenting the measurement results in red/green columns, as well as storing values in a database for each production batch.



Development

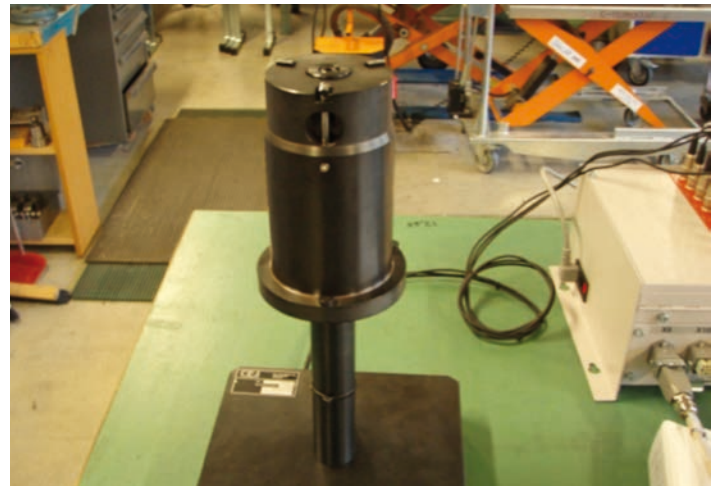

Detailed view

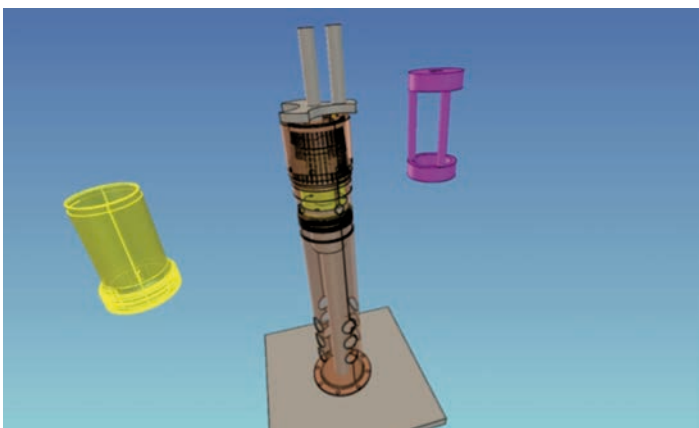

Integration of the piece in a subset

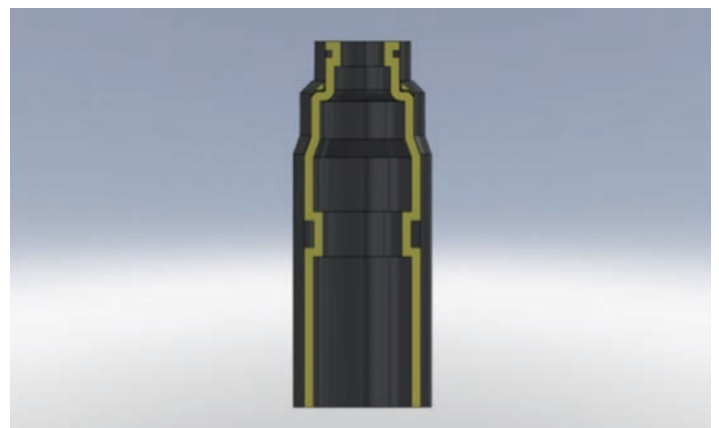

Modelisation of the piece in CAD format



### Technical characteristics

Max dimensions of parts	D = 150 mm L = 400
Transducers	11 Inductive probes
Repeatability of measurement	10% tolerance range
Most restrictive dimension	20 $\mu$ m
Cycle time	30s
Part positioning	Manual
Surroundings	Workshop
Electrical power supply	230V
Measuring computer	SPC VARIO
Measured elements	Internal Diameters 85,5 mm, and concentricity 1 mm

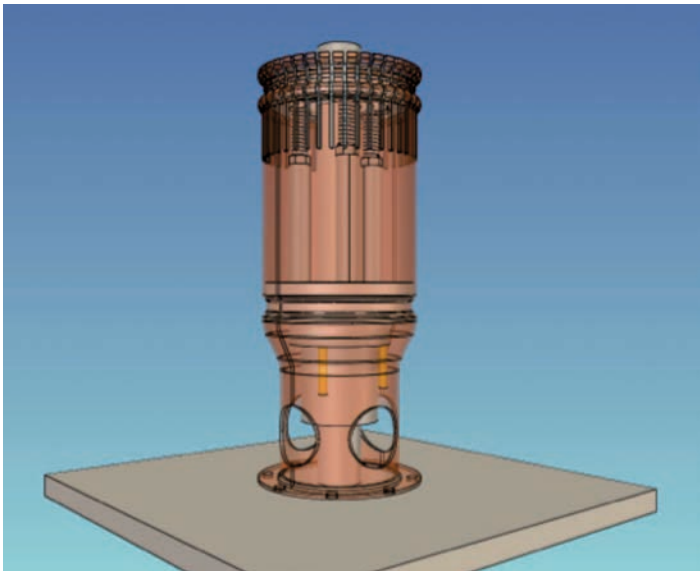

Modelisation CAD

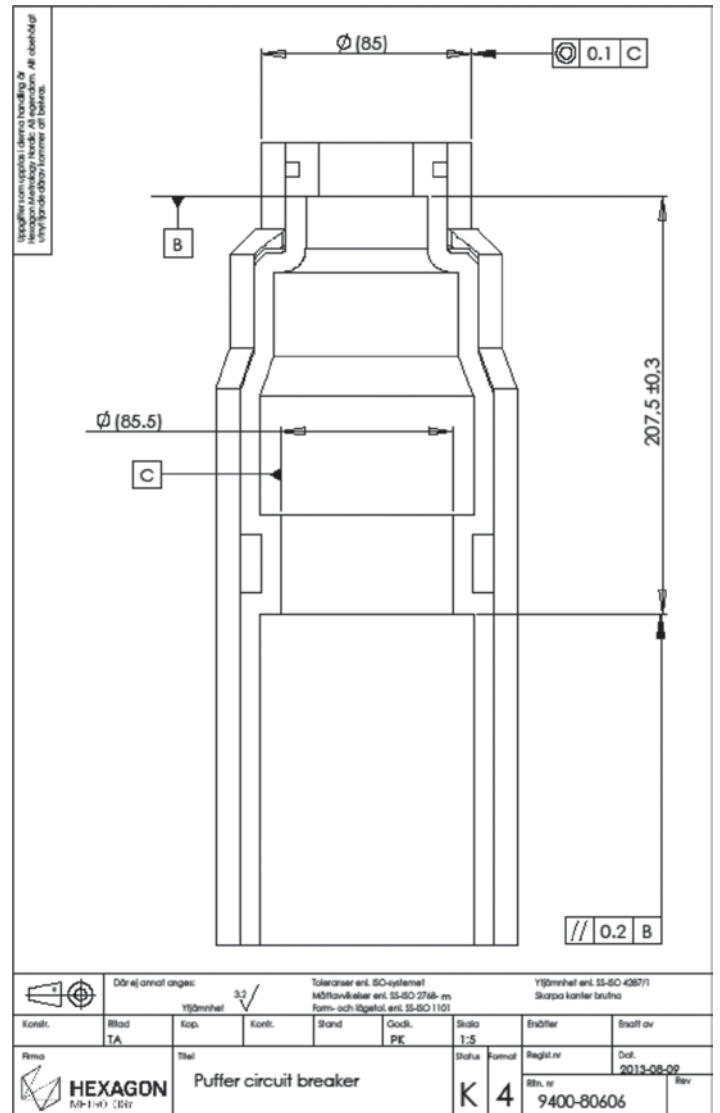

Diagram of measurement plan





Hexagon Manufacturing Intelligence helps industrial manufacturers develop the disruptive technologies of today and the life-changing products of tomorrow. As a leading metrology and manufacturing solution specialist, our expertise in sensing, thinking and acting – the collection, analysis and active use of measurement data – gives our customers the confidence to increase production speed and accelerate productivity while enhancing product quality.

Through a network of local service centres, production facilities and commercial operations across five continents, we are shaping smart change in manufacturing to build a world where quality drives productivity. For more information, visit [HexagonMI.com](http://HexagonMI.com).

Hexagon Manufacturing Intelligence is part of Hexagon (Nasdaq Stockholm: HEXA B; [hexagon.com](http://hexagon.com)), a leading global provider of information technologies that drive quality and productivity across geospatial and industrial enterprise applications.



Established in 1941 and headquartered in Renens, Switzerland, TESA SA manufactures and markets precision measuring instruments that stand for quality, reliability and longevity.

For more than 75 years, TESA has distinguished itself in the market through its excellent products, its unique expertise in micromechanics and precision machining as well as its proven experience in dimensional metrology.

The TESA brand is the global market leader in the field of height gauges and a pioneer thanks to its wide range of instruments, including callipers, micrometers, dial gauges, lever-type dial test indicators and inductive probes.

TESA is a true benchmark for the inspection of incoming goods, as well as for production workshops and quality assurance laboratories.

Through its worldwide distribution network the company focuses on the mechanical engineering, micromechanical, automotive, aerospace, watchmaking and medical industries.

In 2001, TESA became part of Hexagon, a leading global provider of information technologies.

[www.tesatechnology.com](http://www.tesatechnology.com)